

[Print this page](#)

## AASEC 2020

The 5th Annual Applied Science and Engineering Conference

Mason Pine Hotel, 20-21 April 2020

Website: <http://aasec.conference.upi.edu/2020>

Email: [aasec@upi.edu](mailto:aasec@upi.edu)

Date: 13 March 2020

### Letter of Invitation

Dear Authors: Agung Prijo Budijono, Syeihhan Syahrul Syah, Wahyu Dwi Kurniawan, Bidya Nur Habib

We are pleased to inform you that your abstract (ABS-980, Oral Presentation), entitled:

**"Reverse Engineering of Automatic Flouring Machine"**

has been reviewed and accepted to be presented at AASEC 2020 conference to be held on 20-21 April 2020 in Bandung Barat, Indonesia.

We cordially invite you to attend our conference and present your research described in the abstract.

Please submit your full paper and make the payment for registration fee before the deadlines, visit our website for more information.

Thank You.

Best regards,

A handwritten signature in black ink, appearing to read "Ade Gafar Abdullah".

Prof. Dr. Ade Gafar Abdullah, M.Si.  
AASEC 2020 Chairperson



Konfrenzi.com - Conference Management System

PAPER • OPEN ACCESS

## Reverse engineering method to build automatic flouring gauge machine

To cite this article: A P Budijono *et al* 2021 *IOP Conf. Ser.: Mater. Sci. Eng.* **1098** 062108

View the [article online](#) for updates and enhancements.

You may also like

- [Research on Application of Reverse Engineering and 3D Printing Technology in Object Recognition](#)  
Shuang Lin and Xuezhi Shi
- [3D Machine Vision and Additive Manufacturing: Concurrent Product and Process Development](#)  
Ismet P Ilyas
- [An approach to Reverse Engineering Methodology for Part Reconstruction with Additive Manufacturing](#)  
J López and C Vila



The advertisement features a dark blue background on the left with white and orange text, and a photograph of a woman at a podium on the right. The woman is smiling and looking towards the camera, wearing a black top and light-colored pants. The podium has a laptop on it. The background of the photo is a bright, modern interior.

**ECS** The Electrochemical Society  
Advancing solid state & electrochemical science & technology

243rd Meeting with SOFC-XVIII

Boston, MA • May 28 – June 2, 2023

**Accelerate scientific discovery!**

**Learn More & Register**

# Reverse engineering method to build automatic flouring gauge machine

**A P Budijono\*, S S Syah, W D Kurniawan and B N Habib**

Department of Mechanical Engineering, Faculty of Engineering, State University of Surabaya, Ketintang Road, Surabaya 60231, Indonesia

\*agungprijobudijono@gmail.com

**Abstract.** Reverse engineering in development product is the process to re-measure existing product to gain information on it, then redesign the CAD model. It represents geometric shapes and other information of the original one's and used for analyzing, recovery, production, and testing. The model that is created using reverse engineering are for various reasons including to design tool for the production of a copy of an object, to study the concept of an existing design, or to analyze the design for improvement. In this research, it will be re-modeling the automatic flour gauge machine after reviewing the working principle of the machine. The components that will be analyzed and redesigned are: 1) Hooper design for repairing and cleaning operations, 2) Auger design to overcome the fall of flour droplets from the output hole, 3) The design of the Steering Agitator to overcome the nature of the flour adhering to the wall and maintain the flowrate of the flour. The method used were: 1) Determination of Reverse Engineering Components, 2) Identification of Components, 3) Three (3) Dimensional - Component Design. The result showed after the modification of flour in the tube was denser so that it would increase the precision in the filling process, this was because the flowrate became more stable.

## 1. Introduction

Reverse Engineering (RE) is the process of extracting knowledge about design information from anything created. The existing technology or component is the key to apply the process. Deconstructing to know more knowledge from it so that duplication of product can be obtained [1]. RE used to describe about product development by reverse order. RE is very useful to analyze or identify system component of product and build new modified form. The fields of RE consist of mechanical designs, automotive, and consumer product. Especially related to machines, remanufacturing old one's to valuable one's is good enough to increase the advantages [2]. Measuring an existing object or product, then use parametric modelling to generate solid model in order to build the new one's become principle of RE [3]. RE become the greatest way to keep sustainability of product. When RE is applied in large scale such as industrial area, the impact related to: 1) Build new design and new component from previous one's, 2) Production documentation of component can be obtained from reproduction of existing one's, 3) Improvement for precision of product can be finished, 4) Numerical analysis of component / product get better because the engineer can compare the new one's and the previous one's. Several researcher presents a study of reverse engineering, as follows, Elizondo and Reinert [4] have presented about the limitation and obstacles gained by using RE combined with Additive Manufacturing (AM) to build spare part of an aircraft's wing holder. The limitation lies on the accuracy or type of replicable structures mainly depend on hardware and software used. Combination of RE and AM to build wing holder of



Content from this work may be used under the terms of the [Creative Commons Attribution 3.0 licence](https://creativecommons.org/licenses/by/3.0/). Any further distribution of this work must maintain attribution to the author(s) and the title of the work, journal citation and DOI.

aircraft must rely on those hardware and software. Bagci [3] showed that RE can be used for recovery of broken parts. It was created by using CAD models and data digitization method used CMM. CAD models obtained earlier are transferred into CAM module. Then, the parts are manufactured with CNC milling machine. Fei et al. [5] showed that an improvement is made to difference elaborate technology to make it compatible for 2D-CAD engineering graphics. Chintala and Gudimetla [6] have presented that Titanium is the best material for turbine blade using RE and FEA. Titanium offers a safety factor of more than 20% of normal centrifugal force. Lin et al. [7] have presented RE of CAD model reconstruction artificial joint. The process of reverse engineering for model reconstruction consist of physical model, digital model, point pre-processing, surface fitting, 3D solid modelling and CAM processing. Engel and Al-Maeni [8] have showed tht RE also can be combined with failure analysis to be able to recover mechanical shafts. RE and FEA used to understand mechanical behaviour of the previous shaft designed. RE will greatly reduce production time and costs. It also has rapid sustainability of CAD models, then it is used as the starting point and decreased growth process [9,10]. The difference between forward engineering and reverse engineering is that FE is the process of physical implementation from an abstract concept to a design model, whereas RE is a process that is obtained by adjusting and modifying the parameters of the object model features [9]. In this research, it will be re-modeling the automatic flour gauge machine after reviewing the working principle of the machine. The components that will be analyzed and redesigned are: 1) Hooper design for repairing and cleaning operations, 2) Auger design to overcome the fall of flour droplets from the output hole, 3) The design of the Steering Agitator to overcome the nature of the flour adhering to the wall and maintain the flowrate of the flour.

## 2. Literature review

### 2.1. Reverse engineering

This term used in development product to assess previous product to gain information of it, then redesign the model with parametric modelling software. It represent geometric form and other information of the original one's and used for outlining, recovery, production, and verifying [9]. The model that is created using reverse engineering are for various reasons including to design tool for duplicating an object, to enhance the design of an existing one's, or to analyze the design for improvement. Reverse engineering commonly begin with assessing an existing product, in order to a solid model can be built with CAD/CAM/CAE [11]. Reverse engineering is the greatest way to overcome the product necessary of consumer. It is related to sustainability of products. The issue of product sustainability is very important because it is one of the greatest necessary which is needed by modern people [2].

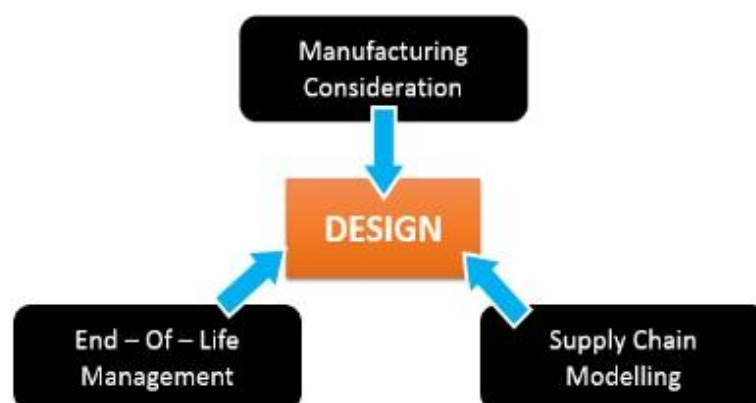

**Figure 1.** Sustainability of product's life.

Reverse engineering has four stages in its development of the technical data to support the efficient use to improve man-made productivity [12].

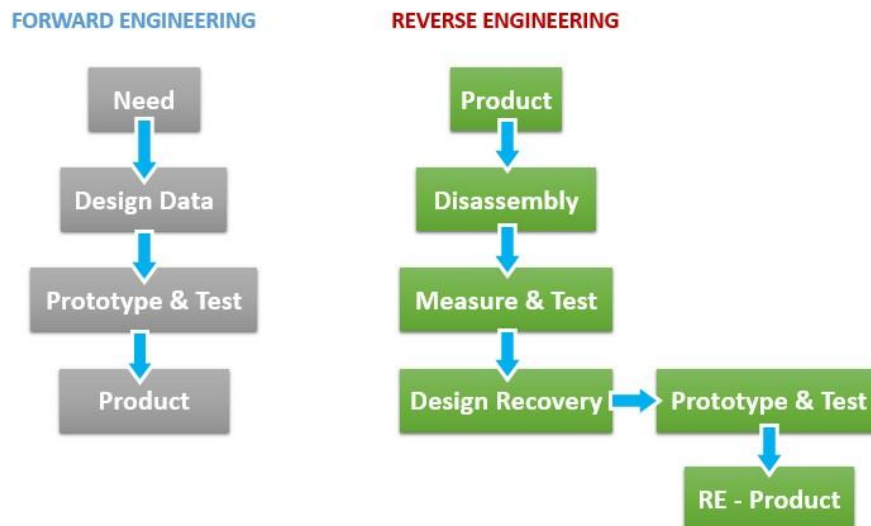

**Figure 2.** Forward engineering versus reverse engineering.

Technical datas of product design can be expanded with RE. They will expand after evaluating, generating, verifying and applying [13].

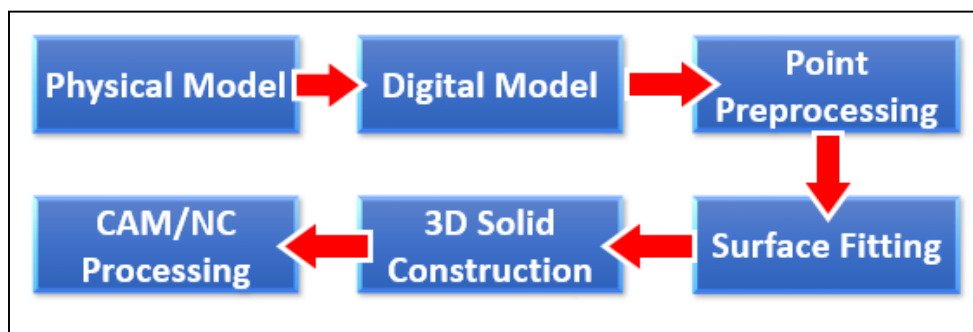

**Figure 3.** The process of reverse engineering.

*2.2. Automatic flouring gauge machine used for reverse engineering*

Automatic Flouring Gauge Machine used for reverse engineering is Fillmach S01P. The machine uses the auger filler system as the main filling system. This machine uses a weight base that is converted to units of time as the filling control system.

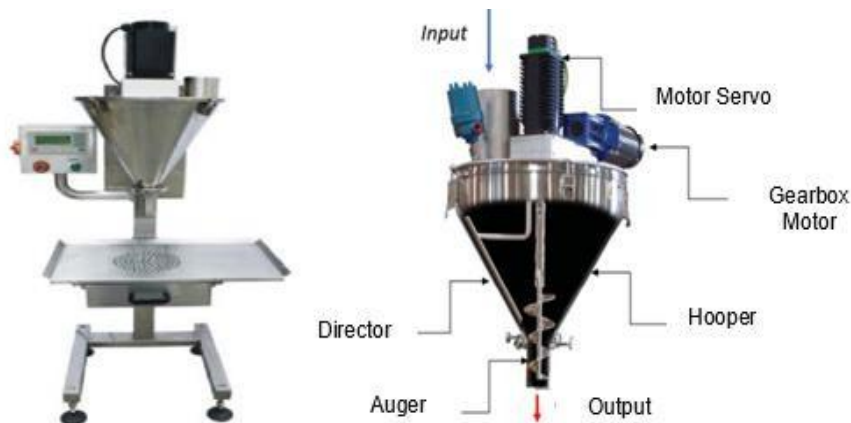

**Figure 4.** Fillmach S01P.

The biggest advantage of the auger filling machine is that the system is relatively closed so that the auger filler is an ideal choice for very fine powders such as talc, flour, and baking soda which tend to air with other systems. This mechanism uses weight and time as a principle of gauging. It can be used for the product which has small size of granule and flour. In some cases, auger filler mechanism can be used as a filler for rice and pasta.

### 3. Research methods

Research method used as follows:

#### 3.1. Determination of reverse engineering components

The component design of Fillmach S01P will be used to assemble the three-dimensional design in this study so that complex flour measuring machines can be produced.

#### 3.2. Identification of components

Automatic Flouring Gauge Machine which has become a reference for reverse engineering has been dismantled in the previous study conducted identification. Identification of measurements carried out on each component to be redrawn. Identification is carried out to find out what components must be redesigned to be assembled in the design of a flour baking machine. In addition to identification also done to understand how the flour measuring machine works and what equipment is on the machine.



**Figure 5.** Agitator and Auger components.



**Figure 6.** The transmission of automatic flouring gauge machine.



**Figure 7.** Hooper of automatic flouring gauge machine.

*3.3. Three (3) dimensional - component design*

Through the component identification process, it can be seen which components need to be redesigned and the component dimensions. When making component designs the things to consider are the distance between the components, the clearance and also the position of the components. Because in this study the design of Automatic Flouring Gauge Machine that can be assembled is needed.

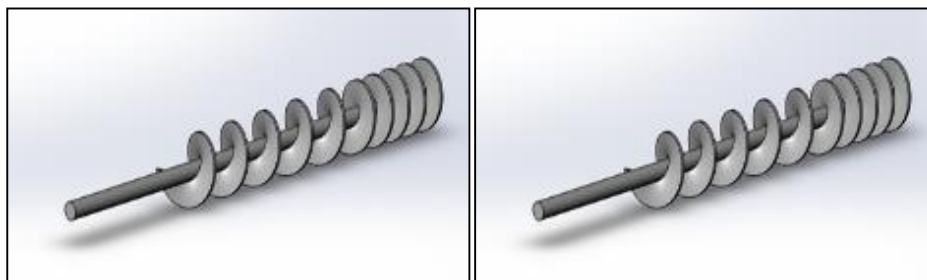

**Figure 8.** Redesign of Auger.

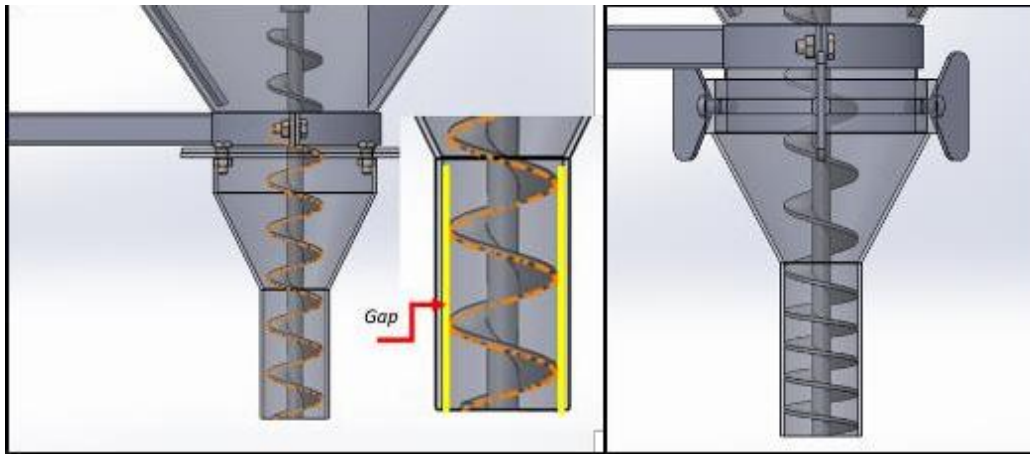

Figure 9. Redesign of Hooper.

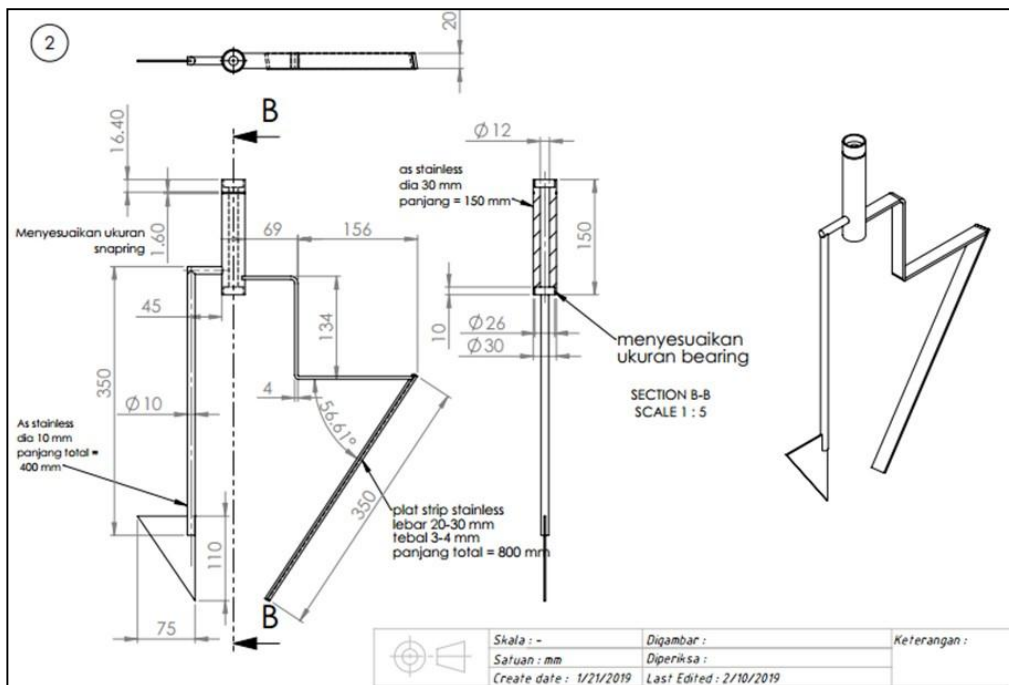

Figure 10. Redesign of Agitator.

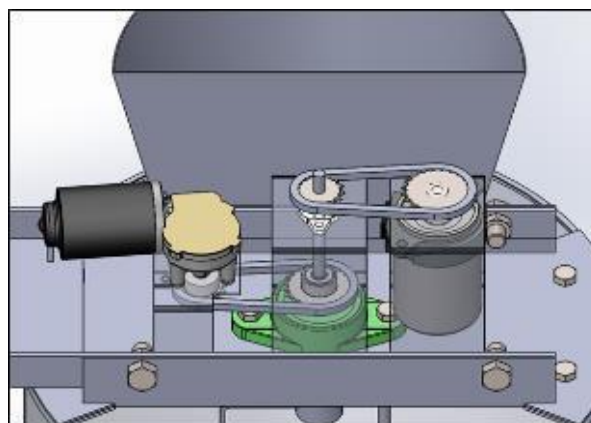

Figure 11. Redesign of transmission.



## 4. Result and discussion

### 4.1. Design analysis

In this section an analysis of the model that has been made had an intention to find out whether there were errors in the design that make the machine could not be assembled. The particle motion simulation was carried out to determine the movement of flour before and after the modification. This simulation intended to see the differences in the movement of particles that was influenced by the design of Auger and the agitator and then did a visual analysis.

**Table 1.** Test parameters for the Agitator component.

No.	Parameter	Dimension
1.	Time	0 s
2.	Rotating speed	20 rpm
3.	Acceleration	0 deg/s <sup>2</sup>
4.	Vector axis / direction of rotation	X = 32.7 , Z = 508, CW

**Table 2.** Test parameters for Auger component.

No.	Parameter	Dimension
1.	Time	2 s
2.	Rotating speed	500 rpm
3.	Acceleration	0 deg/s <sup>2</sup>
4.	Vector axis / direction of rotation	X = 32.7 , Z = 508, CW

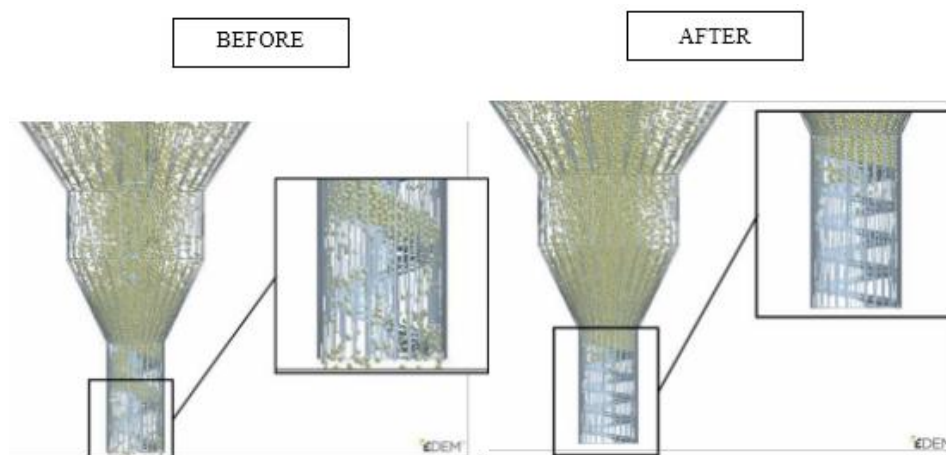

**Figure 12.** Simulation of flour particles before and after reverse engineering.

After a modification to Auger, it could be seen that the problem of flour leakage has not been seen. It was because the diameter size of Auger coincides with the output pipe so as to prevent flour leakage. During the operation phase of the machine, before modification there were cavities that have not been filled with flour, this causes flour in the output tube to be less dense which will affect the accuracy of the machine in the filling process. After the modification of flour in the tube was denser so that it would increase the precision in the filling process, this was because the flowrate became more stable.

**Table 3.** Comparison of simulation results before and after modification.

No.	Indicators	Before Reverse Engineering	After Reverse Engineering
1.	Flour leaks	Leak	Not Leak
2.	Density	Less dense (hollow)	dense
3.	Flow (Q)	Inconsistent	More consistent

## 5. Conclusion

The design of the agitator with the additional modification of the Teflon that can be adjusted to the crush distance from the surface of the input funnel can sweep the flour well so that the flour can shift and not stick to the surface of the input funnel. The Auger design with different pitch dimensions modification produces flour density in the output tube, so that flow flow is more consistent which will increase the precision of the filling process.

## References

- [1] Eilam E 2011 *Reversing: secrets of reverse engineering* (John Wiley & Sons)
- [2] Ramani K, Ramanujan D, Bernstein W Z, Zhao F, Sutherland J, Handwerker C, Thurston D 2010 Integrated sustainable life cycle design: A Review *Journal of Mechanical Design, Transactions of the ASME* **132** 0910041–09100415
- [3] Bagci E 2009 Reverse engineering applications for recovery of broken or worn parts and re-manufacturing: Three case studies *Advances in Engineering Software* **40** 407–418
- [4] Elizondo A and Reinert F 2020 ScienceDirect ScienceDirect Limits and hurdles of Reverse Engineering for the replication of Limits and hurdles of Reverse Engineering for the replication of parts by Additive Manufacturing ( Selective Laser Melting ) parts by Additive Manufacturing (Selective Laser Melting) *Procedia Manufacturing* **41** 1009–1016
- [5] Fei P, Yu-zhou L, Min L and Xing-ming S 2011 Computer-Aided Design A reversible watermarking scheme for two-dimensional CAD engineering graphics based on improved difference expansion *Computer-Aided Design* **43** 1018–1024
- [6] Chintala G and Gudimetla P 2014 *ScienceDirect Optimum material evaluation for gas turbine blade using Reverse Engineering (RE) and FEA* **97** 1332–1340
- [7] Lin Y, Wang C and Dai K 2005 *Reverse engineering in CAD model reconstruction of customized artificial joint* **27** 189–193
- [8] Engel B and Al-Maeeni S S H 2019 An integrated reverse engineering and failure analysis approach for recovery of mechanical shafts *Procedia CIRP* **81** 1083–1088
- [9] Yuan X, Zhenrong X and Haibin W 2001 Research on integrated reverse engineering technology for forming sheet metal with a freeform surface **112** 153–156
- [10] Ciocănea A, Nicolaie S and Băbuțanu C 2017 Reverse engineering for the rotor blades of a horizontal axis micro-hydrokinetic turbine *Energy Procedia* **112** 35-42
- [11] Martin R R 1997 Reverse engineering geometric models-an introduction *Computer-aided design* **29** 255–268
- [12] Kathryn A Ingle 1994 *Reverse Engineering, New York* (McGraw Hill Inc)
- [13] Ke Y L, Xiao Y X and Li J X 2001 The research of reverse engineering CAD modelling technique *J Comput Aided Des Graph* **13** 570-5